



M3500-OPT09 20-Channel Scanner Card USER'S GUIDE

October 2020 Version 2.3 Printed in Taiwan

PICOTEST CORP.

8F-1, 286-9, Hsin-Ya Rd., 80673, Kaoshiung, Taiwan
 TEL: +886-7-815-7183
 FAX: +886-7-815-8312
 URL <http://www.picotest.com.tw>

Product Introduction

PICOTEST thanks you for purchasing the "M3500-OPT09 (20-channel Scanner Card)". To obtain the best performance from the product, please read this guide carefully.

1. Overview

The M3500-OPT09 provides the measurements including 2-/4-wired Ohm, Voltage, Freq., Period, and indirect Current (Shunt via Software's MX+B).

2. Inspection & Cleaning

Inspection:

- This card includes a set of output probes.
- When you open the package, inspect it carefully to make sure whether defects occur on the appearance or malfunctions appear in the operation. Please contact with your local reseller or PICOTEST representative for more help.

Cleaning:

To clean the card, use a damp cloth or mild, water based cleaner. Clean the surface of the cover only. Do not apply cleaner on the circuit board directly or allow liquids to enter or spill on it.

3. Safety

This safety information with the warning and danger marks on the user's guide reminds users to avoid risks as they are using it.

Warning: The triangle symbol in black indicates that incorrect operation might cause an injury to users or damage to the product.

Danger: The triangle symbol in red indicates that incorrect operation might cause an extreme hazard to users' life.

4. Warning

Danger

- To avoid electrical shock and personal injury, please don't exceed the ratings provided.
- The maximum AC voltage is 110V rms or 155V peak, 100kHz, 1A switched 30VA (resistive load), and DC voltage is 110V, 1A switched, 30VA (resistive load).

Warning

- To avoid damaging the product, please do not pull it away when measurement is executed.

5. Specifications

Maximum AC Voltage	110V rms or 155V peak, 100kHz, 1A switched, 30VA (resistive load)
Maximum DC Voltage	110V, 1A switched, 30VA (resistive load)
Contact Life	>100000 operations at maximum signal level; >100000000 operations cold switching.
Contact Resistance	<1ohm at end of contact life
Actuation Time	5ms maximum on/off
Contact Potential	<±500nV typical per contact, 1µV max <±500nV typical per contact pair, 1µV max
Connector Type	Screw terminal, #22 AWG wire size
Isolation btw Any Two terminals	>10 Gohm, < 75pF
Isolation btw Any Terminal and Earth	>10 Gohm, < 150pF
Common Mode Voltage	200V peak btw any terminal and earth

Max. Voltage btw Any Two Terminals	160V peak
Max. Voltage btw Any Terminal and M3500A Input LO	160V peak
Environmental	Meets all M3500A Environmental Spec.

6. Performance

Rate of the Scanner Card Measurement				
AutoZero OFF, AutoGain OFF, AutoRange OFF, Scan Timer=0,60Hz				
	NPLC	Acquisition Time with 2000 Readings(sec)	rate(ch/s)	
single function(VDC)	(Fast 4.5)	0.02	68	29.4
	(Slow 4.5 & Fast 5.5)	0.1	74	27.0
	(Slow 5.5 & Fast 6.5)	1	105	19.0
	(Slow 6.5)	10	408	4.9
Mix function (VDC+2WRES)	NPLC	Acquisition Time with 2000 Readings(sec)	rate(ch/s)	
	(Fast 4.5)	0.02	306	6.5
	(Slow 4.5 & Fast 5.5)	0.1	318	6.3
	(Slow 5.5 & Fast 6.5)	1	442	4.5
(Slow 6.5)	10	1710	1.2	

7. SCPI Commands

Command	Description
ROUTE:CLOSE <channel>	Close channels <1 ~ 20>.
ROUTE:CLOSE?	Query the closed channels
ROUTE:OPEN	Open all channels.
ROUTE:STATE?	Ask the state. The state 2 means Card inserted or 0 means Card not inserted.
ROUTE:SCAN:FUNCTION <channel>,{<function>["VOLT:DC" "VOLT:AC" "FREQ RESistance" "FRESistance" "NONE"]}	Set card states which might measure the VAC, VDC, Frequency, 2-Wire Resistance, 4-Wire Resistance or disabling the channel.
ROUTE:SCAN:FUNC? <channel>	Ask the channel's state of the card.
ROUTE:SCAN:TIMER?	Read the time interval of scanning.
ROUTE:SCAN:TIMER <value>	Set the time interval of scanning <The unit is second>.
ROUTE:SCAN:COUNT?	Read the number of times of scanning.
ROUTE:SCAN:COUNT <value>	Set the number of times of scanning.
ROUTE:SCAN:STATE?	Read the state of scanning. 1 means "finished". 0 means "not finished".
ROUTE:SCAN:SCAN	Run SCAN mode
ROUTE:SCAN:STEP	Run STEP mode

8. Measurements

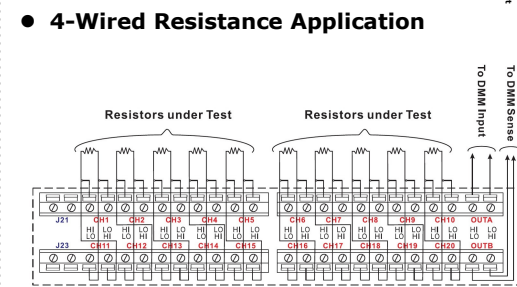
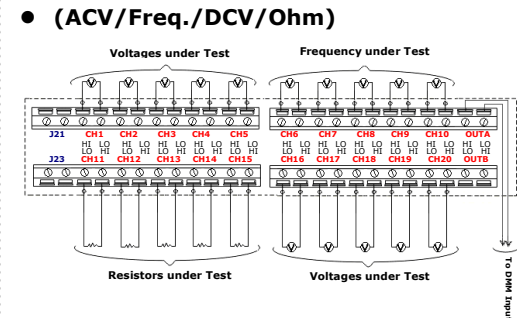

Output B is only used for 4-wired resistance measurements.

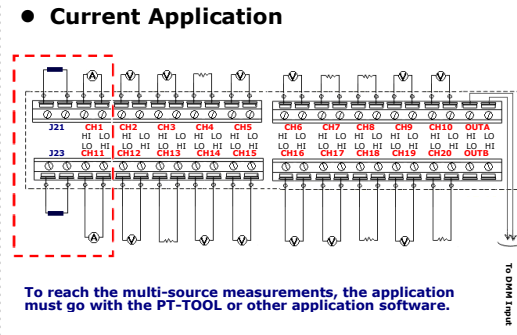

To reach the multi-source measurements, the application must go with the PT-TOOL or other application software.

- * Note 1: CH1 & CH11 can be used on other measurements when current shunts are released from J21 & J23.
- * Note 2: The current application is not the direct measurement from real current sources. So to use current measurement via the scanner card, users have to enable DCV/ACV and MX+B functions. Then the scanner card output needs to be connected to the front/rear terminal "Input HI & LO".

The measured current is calculated through the equation as follows. "I=V/R"
 Where: I = Current being determined
 V = Voltage measured by the DMM
 R = Shunt resistance value
 As to the MX+B setting, "M" stands for "1/R", "X" stands for "voltage measured by the DMM" and "B" stands for "Offset, 0".
 For more detailed information, refer to the M3500A user's manual.