

# Power Supply Crosstalk Measurement

Using the Bode 100 and the  
Picotest J2111A Current Injector

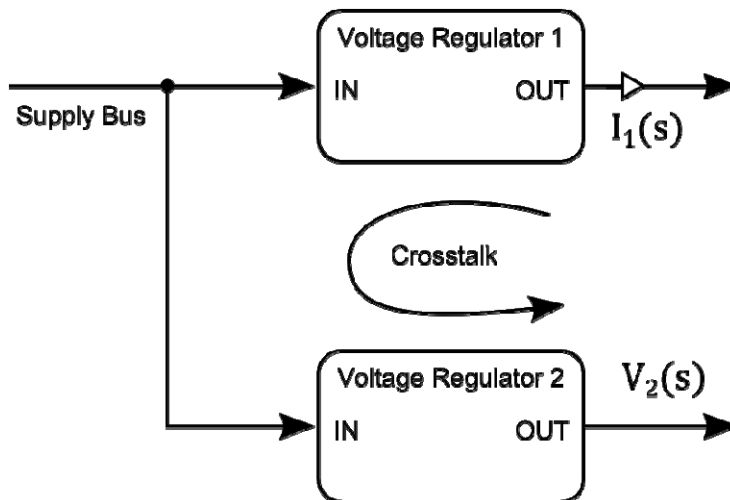
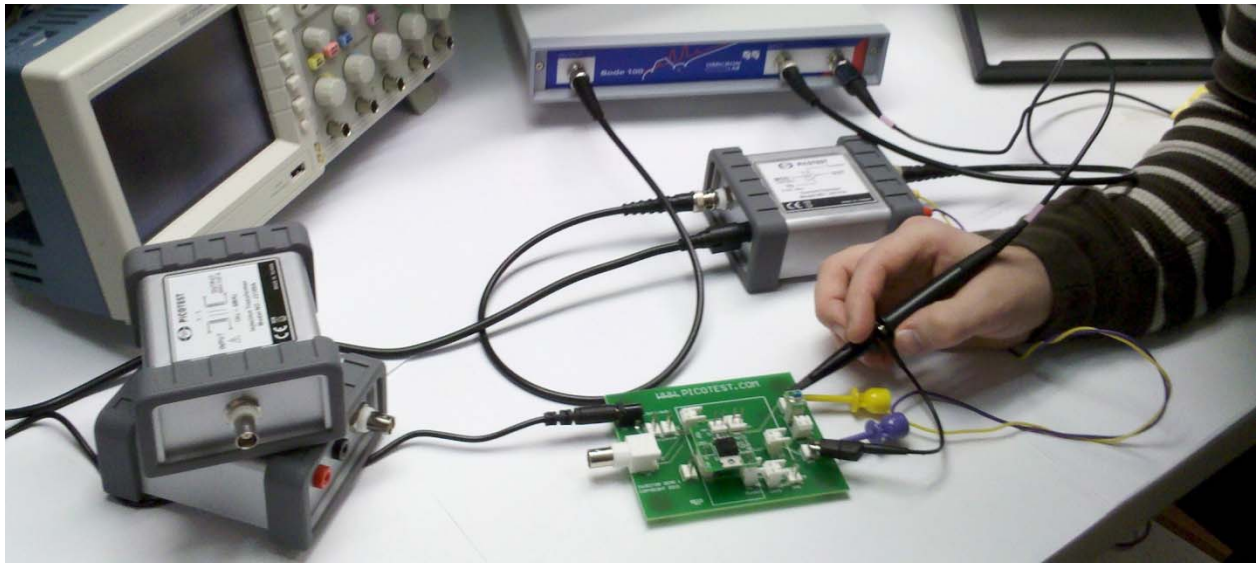

By Florian Hämmerle & Steve Sandler

© 2011 Picotest.com

Visit [www.picotest.com](http://www.picotest.com) for more information.

Contact [support@picotest.com](mailto:support@picotest.com) for technical support.

## Table of Contents

<b>1 Executive Summary .....</b>	<b>3</b>
<b>2 Measurement Setup .....</b>	<b>4</b>
2.1 Device Setup .....	6
2.2 Measurement .....	7
<b>3 Conclusion.....</b>	<b>8</b>

**Notes:** Basic procedures such as setting-up, adjusting and calibrating the Bode 100 are described in the Bode 100 user manual.

The Picotest J2110A Current Injector does not require calibration.

All measurements in this application note have been performed with the OMICRON Lab Bode 100 Analyzer Suite V2.31. Use this version or a higher version to perform the measurements detailed in this application note.

You can download the latest version at <http://www.omicron-lab.com/downloads.html>.

You can download the latest Picotest Injector manual at <https://www.picotest.com/support.html>.

## 1 Executive Summary

This application note shows how the crosstalk characteristic of a system of two linear voltage regulators can be measured using the OMICRON Lab Bode 100 and the Picotest J2111A Current Injector. The same technique can be used to measure switching regulators as well.

The measurements are performed on the Picotest Voltage Regulator Test Standard (VRTS) testing board<sup>1</sup> which comes with the regulators needed to perform the measurements shown in this document. The first regulator is a LM317 variable linear voltage regulator, the second regulator is a fixed voltage regulator (TLV2217).

The VRTS can be used to help performing a high variety of voltage regulator measurements using the Bode 100 in conjunction with the Picotest line of Signal Injectors.

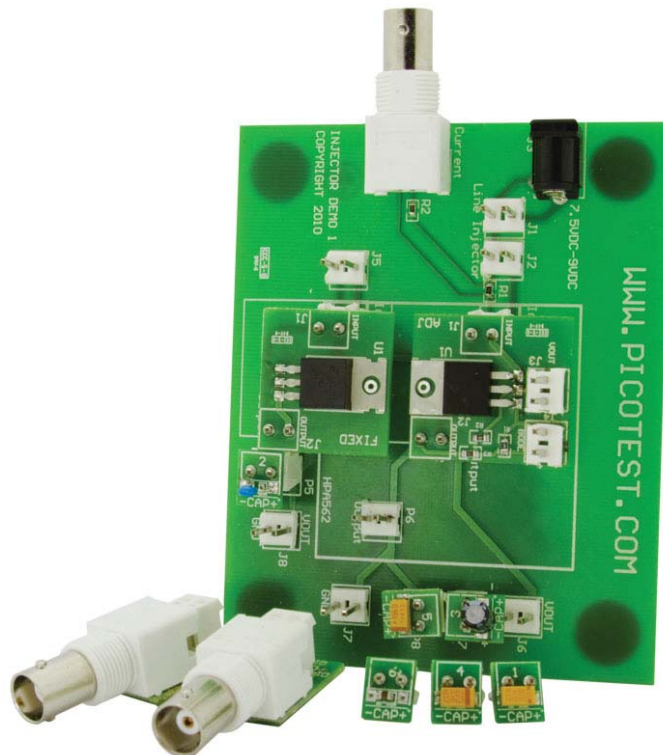

Voltage Regulator Test Standard board, Source (1)

<sup>1</sup> See: [http://www.picotest.com/products\\_injectors.html](http://www.picotest.com/products_injectors.html)

## 2 Measurement Setup

The Crosstalk characteristic is an important parameter of systems with multiple voltage regulators connected on one single supply bus.

It describes how a change in the output current (load current) of one regulator appears as an unwanted voltage change in the output voltage of another regulator.

The crosstalk characteristic  $CT$  is defined by

$$CT = 20 \log \frac{v_2}{i_1}$$

where  $i_1$  is the AC part of the load current of the first voltage regulator and  $v_2$  is the voltage ripple of the output voltage of the second voltage regulator.

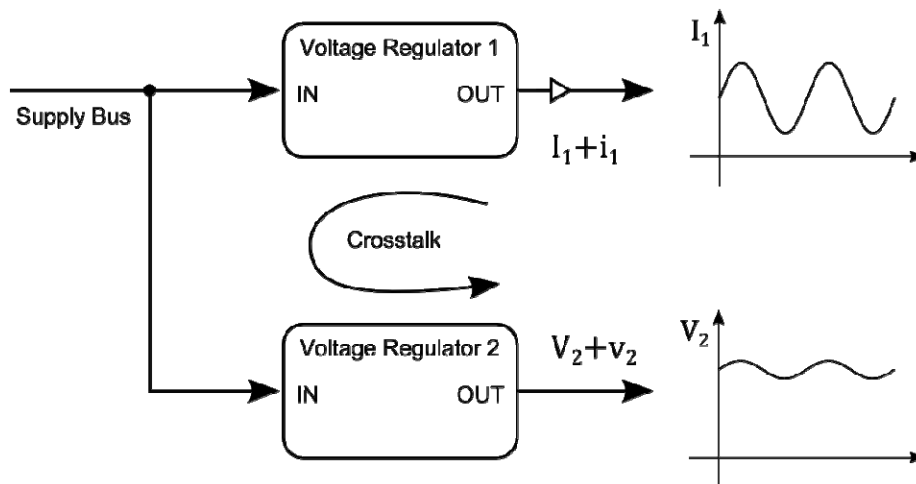

The Crosstalk is closely related to the Reverse Transfer characteristic of the first regulator and the PSRR of the second regulator. Information on how to measure the Reverse Transfer and PSRR can be found under the application note section of our webpage: <http://omicron-lab.com/application-notes.html>

The Crosstalk can be measured by applying a sinusoidal ripple on the load current of the first regulator and measuring the gain factor between the output current and the output voltage ripple of the second regulator.

The Picotest J2111A Current Injector adds a modulated output current, in parallel to any other particular loading that is applied. The added current is modulated according to the sinusoidal output voltage of the Bode 100. The Crosstalk is then measured by comparing the modulated load current with the output voltage of the second voltage regulator.

The following figure shows the crosstalk measurement setup:

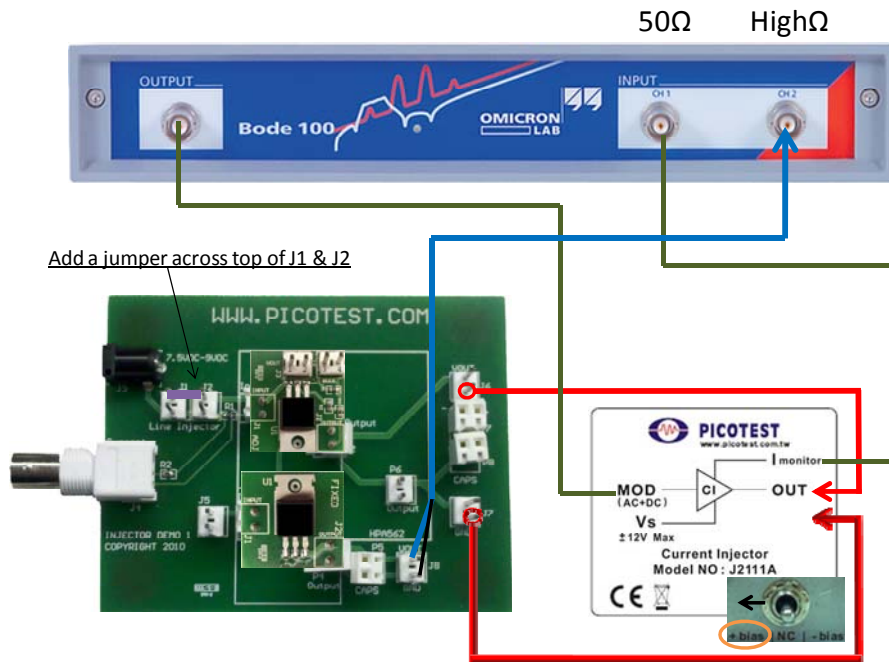

Crosstalk measurement setup, Source: (1)

The J2111A Current Injector can also act as a load for the voltage regulator. To achieve this, switch on the +bias of the J2111A resulting in a constant current load of 25mA. The Bode 100 and the Current Injector are connected to the VRTS board as shown in the following picture:

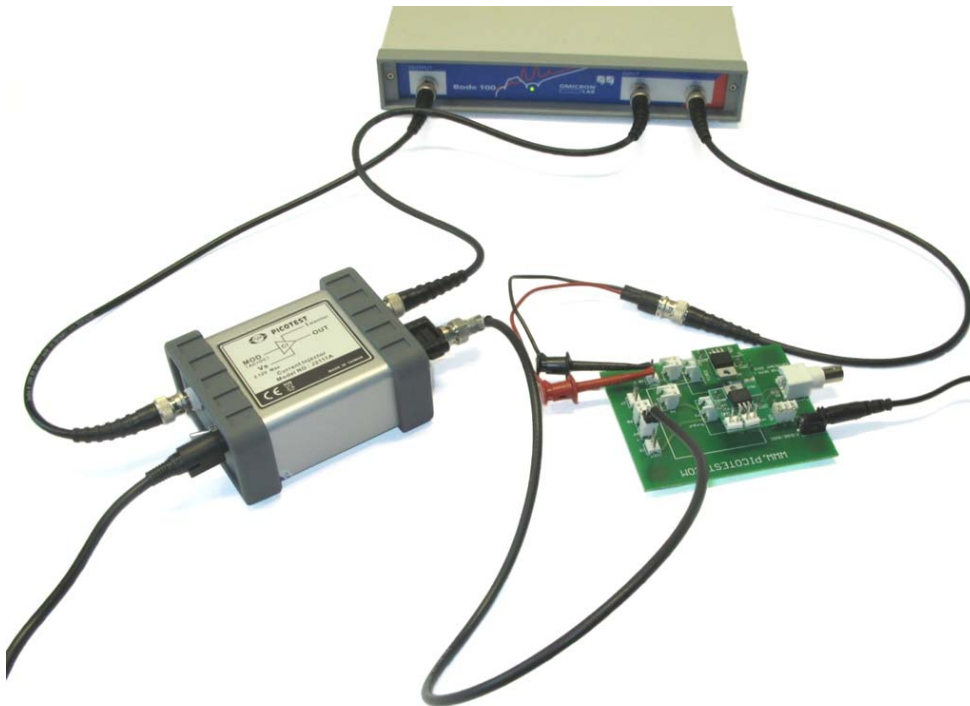

Crosstalk measurement setup example

### 2.1 Device Setup

The crosstalk measurement can be performed directly with the Bode 100 using the external reference function. The Bode 100 is set up as follows:

- Measurement Mode: Frequency Sweep Mode
- Start Frequency: 10 Hz
- Stop Frequency: 10 MHz
- Sweep Mode: Logarithmic
- Number of Points: 201 or more
- Receiver Bandwidth: 100 Hz
- Attenuator 1: 0 dB
- Attenuator 2: 20 dB
- Level: 10 dBm

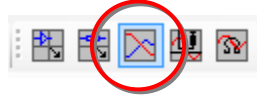

To switch on the external reference start the device configuration window and click on the external reference switch symbol:

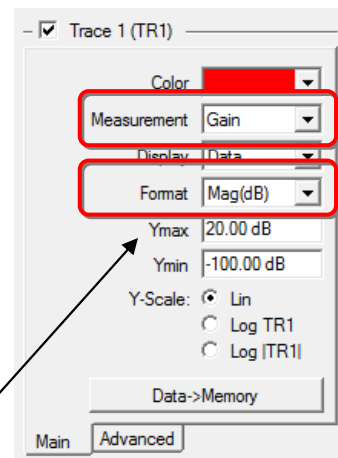
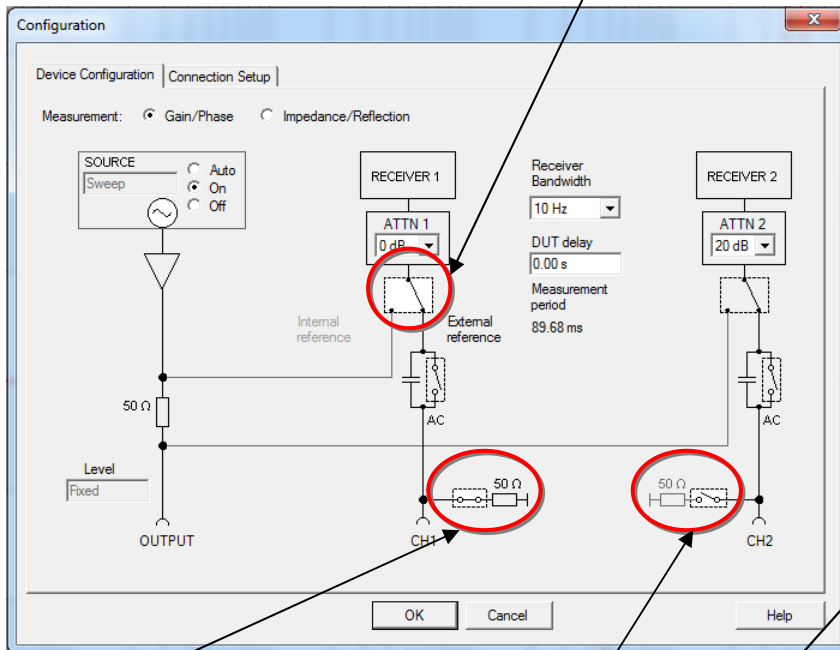

Set channel 1 to 50Ω input impedance and channel 2 to high impedance.

Set Trace 1 Measurement to Gain and Format to Mag(dB).

## 2.2 Measurement

You can get started with the measurement using the setup shown before.

Performing a single sweep leads to the following crosstalk plot:

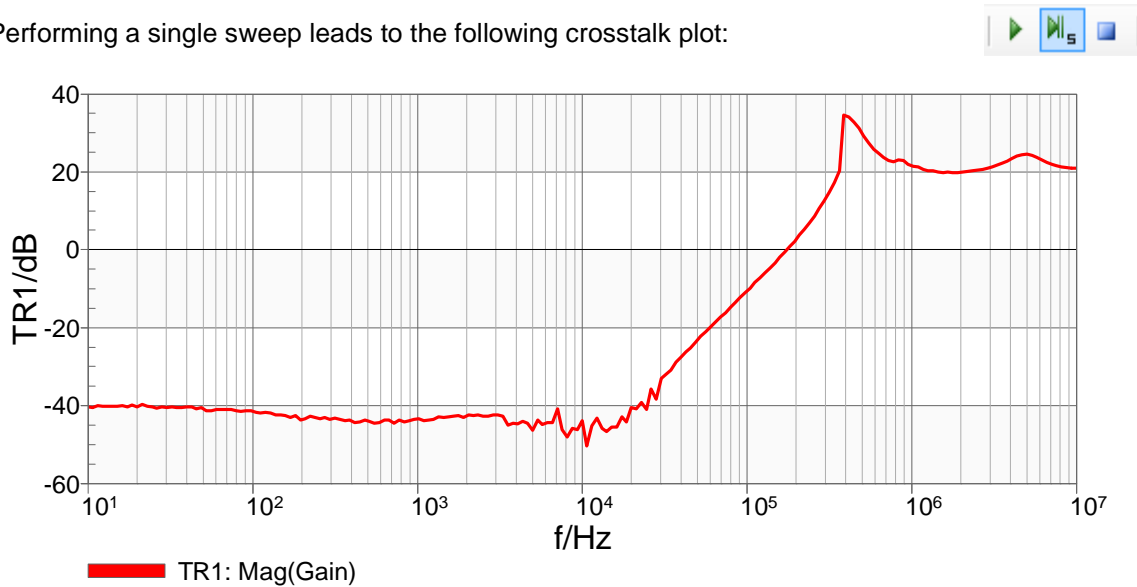

Crosstalk plot 1

From the measurement result can be seen that crosstalk from regulator 1 to regulator 2 is very high in the high frequency range.

### Output Capacitor:

Adding capacitor no. 3 (100 $\mu$ F aluminum capacitor) to the output of the second regulator and restarting the measurement leads to the following result:

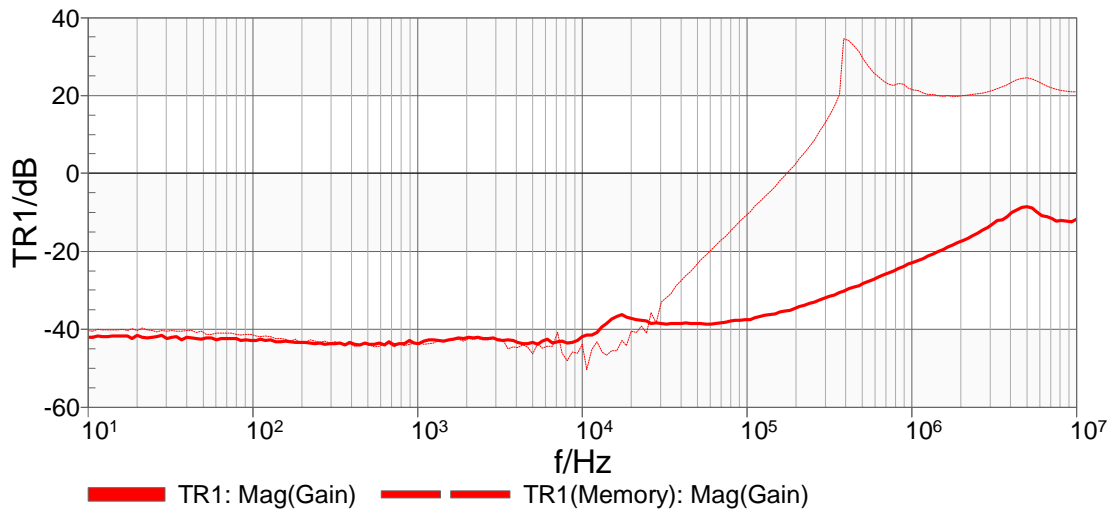

Crosstalk plot 2

The output capacitor of the second regulator reduces the high frequency ripple on the regulator output which results in less crosstalk.

### Directivity:

Reversing the measurement shows that crosstalk characteristic can be directive. The load current excitation is now applied to regulator 2 and the voltage ripple measured at the output of regulator 1. Starting a sweep leads to the following result:

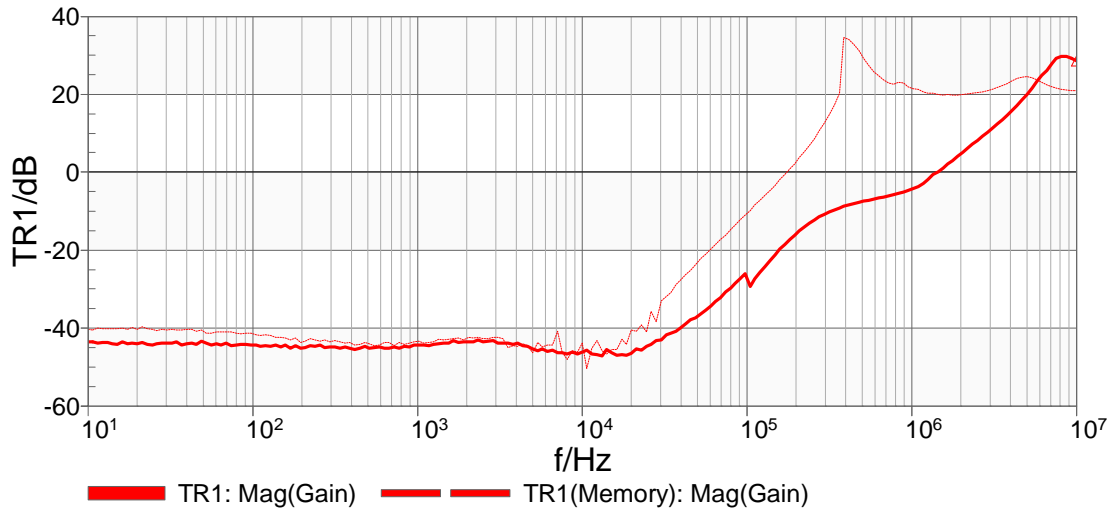

### Crosstalk plot 3

The solid line shows the result for the crosstalk from regulator 2 to regulator 1. The result differs significantly from the previous measurement (dashed line) showing the directivity of the measurement.

## 3 Conclusion

Crosstalk is an important measure for power supply systems with multiple voltage regulators connected to a supply bus. The crosstalk is strongly related to the Reverse Transfer characteristic and the PSRR of the regulators. Input and output filters do strongly influence the crosstalk result.

The Bode 100 in combination with the J2111A Current Injector offers a test set that enables simple and fast crosstalk measurements in a wide frequency range.

## References

1. Picotest. Voltage Regulator Test Standard. Version 1.0d. 2010.
2. Voltage Regulator Test Standard. Version 1.0c. 2010.
3. Signal Injector Documentation. Version 1.0c. 2010.